

# Technik-Plus

**TP-Turbo-Jet Super 12  
TP1230IN**



## **MOUNTING INSTRUCTION**

\*Translation from original\*



**TECHNIK-PLUS SÄMASCHINEN E.U.**

Industrieparkstr. 6-8

A-8480 Mureck

[www.technik-plus.eu](http://www.technik-plus.eu)

[technik-plus@technik-plus.eu](mailto:technik-plus@technik-plus.eu)

Serial no.: \_\_\_\_\_

## **CONTANT:**

<b>Warranty</b>	p. 3
Product liability	p. 3
Description of TP-Turbo-Jet Super 8	p. 3
Technical details	p. 4
Transport information	p. 4
General mounting information	p. 4
Frame for machine	p. 4-7
The speed sensor	p. 8
The ON/OFF-sensor	p. 9
Mounting-possibilities of TP-Turbo-Jet Super 8	p. 10-11

## **Warranty:**

The manufacturer warranty is 1 year and includes the following points:

- Parts damaged as a result false fitting or material defect within this time.
- If you use original spare parts.

Warranty expires in following cases:

- Spare parts, which have to be changed regularly during normal operation (connecting parts).
- Spare parts damaged because of breakdowns, carelessness, misuses and faulty use or installation.
- If you use analogy parts or spare parts from other manufacturers.
- If you do not follow operating and mounting instructions.
- Damages of transport must be announced immediately, at least within 8 days after delivery, through a registered letter.

## **Product liability:**

The product liability covers only corresponding operation. If the seeder is not maintained correctly (eg regulary control of scatter diagram and functionality of particular parts...) the manufacturer assumes no liability.

## **Description:**

TP-Turbo-Jet Super 12 (TP1230IN)

Painting red; 12 outlets; 12 Y-dividers; 24 spreader plates; 40m hose; seedroll motor with one speed; Hydraulic driven fan: 1 turbine diam 380mm; agitator; hopper 300lit. with cover; standard seed roll - mounted; grass seed roll; seed roll for small amount - 10mm; Multifunctional control unit with speed sensor and on/off sensor;

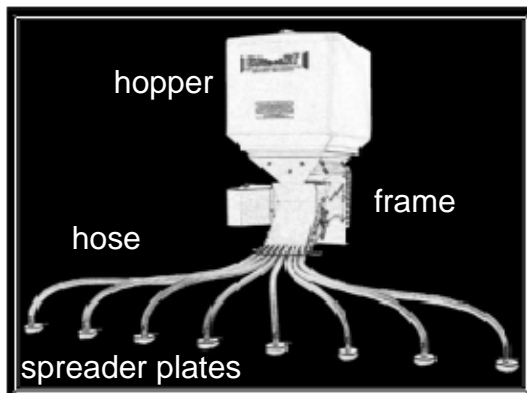

Sample picture

### **Technical details:**

Please see data sheet.

### **Transport information:**

The TP-TURBO-JET SUPER 12 can be lifted on the 4 butt straps. Please note that all 4 butt straps have to be of the same length and strength when lifting the planting attachment (min. load 120 kg). On various lengths the spreader may tilt over.

You can also use the framework for lifting the spreader. Please note here again that all 4 butt straps have to be of the same length and strength when lifting the planting attachment (min. 120 kg). If you use just 2 carrying straps for lifting the spreader the points at which the spreader on the frame will be lifted have to be located exactly in the middle.

### **General mounting information:**

Please study this mounting instruction carefully before fitting to the devices. With TP-TURBO JET SUPER 12 it is possible to spread a high number of seeds and granulates in combination with fitting of a great number of devices. It is useful to develop special fitting parts for any device. The advantage of a special fitting is the adequate assembling to each requirement.

The installation of plastic hopper, spreader plates and hoses depends upon the design and type of the device. Some ideas for correct working with TP-TURBO-JET SUPER 12 are given below.

### **Frame for machine:**

Each implement needs a special fitted frame. When constructing the frame take care of following points:

1. The frame must carry **min. 700kg**.
2. If you fit the machine on a folded implement, take care that there is enough space.

Enough space!

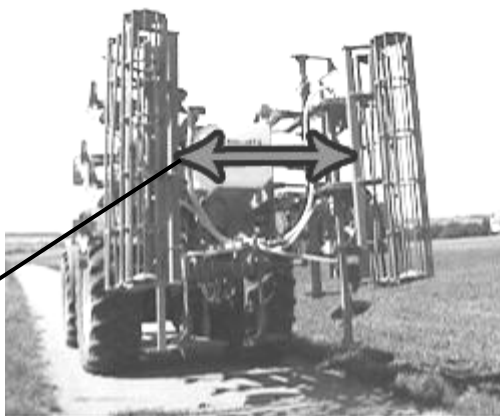

3. The optimal mounting height depends. If you mount the TP-Turbo-Jet Super up to 3m the hoses can lead nearly flat to the sprayer plates. From 3-max.4m with bigger seeds (like mustard, oat, wheat, ...) the hoses must lead downwards. Up to 6m with small seed (like grass, clover, rape, ...) the hoses can lead very flat.

Possible for: Rye,  
Grass, clover, mustard,  
rape, phacelia, oilradish,  
lucerne, vetch, pea, oat,  
buckwheat, wheat,  
barley, sunflower, bean,  
... up to 3m

Hoses can be nearly flat.

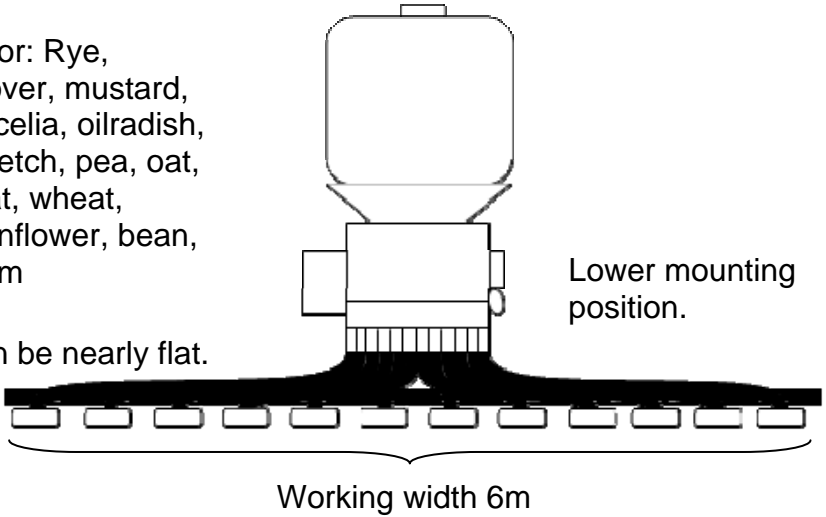

Possible for: Rye,  
Grass, clover, mustard,  
rape, phacelia, oilradish,  
lucerne, vetch, pea, oat,  
buckwheat, wheat,  
barley, sunflower, bean,  
... up to 4m

Hoses must be downwards.

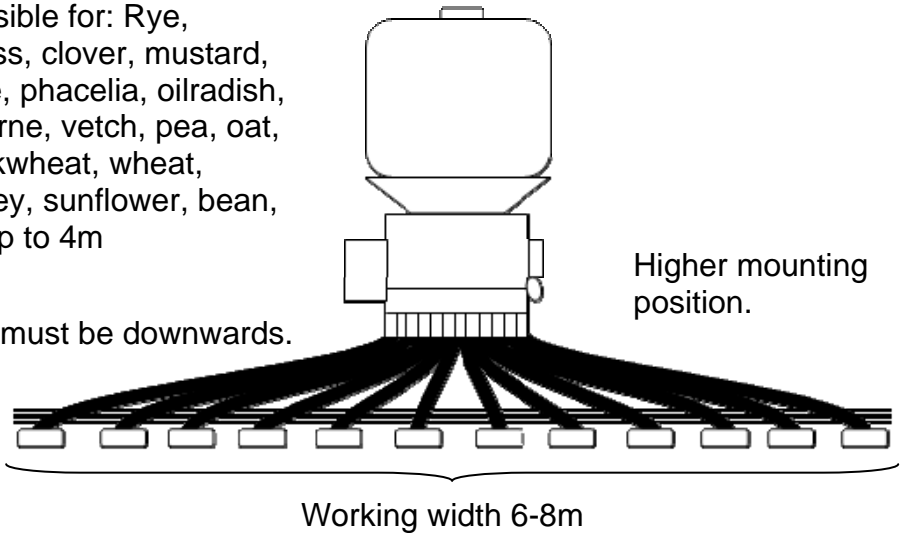

Symbols:

Implement 

Seeder 

Spreader plate 

Hose 

Possible for: Grass, clover, mustard, rape, phacelia, oilradish, lucerne, ... up to 6m

Hoses can be nearly flat.

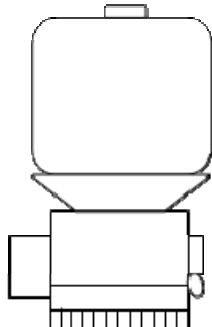

Lower mounting position.



Working width 12m

It is advisable to choose a lower mounting position. Hopper filling would be easier. In any case (if mounted low or high), you must mount steps to fill in the hopper. The steps to the tank for filling are to be designed according to the DIN EN 14018 (You can get the German industrial standard at our firm on request).

4. Take care, that there is enough space beyond the seeder to open the cover for collecting the seed.

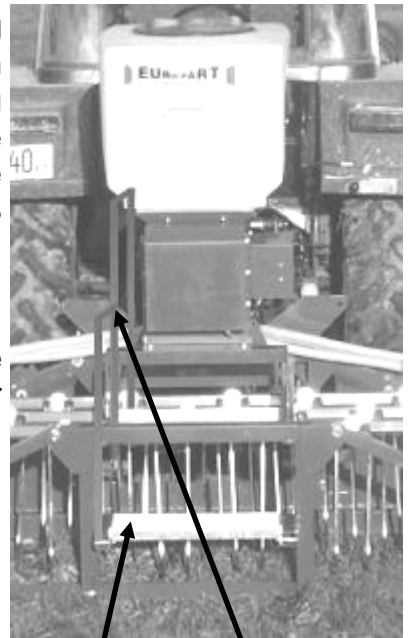

Steps and handrail



Cover must be possible to open!

5. Please avoid clamping the hoses, when the machine is fitted on a folded implement.

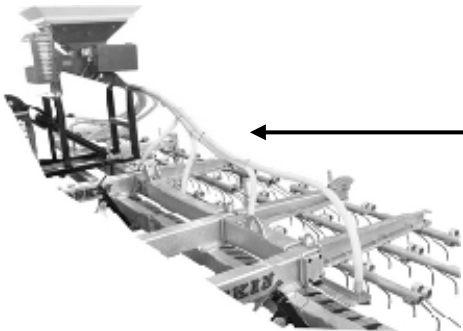
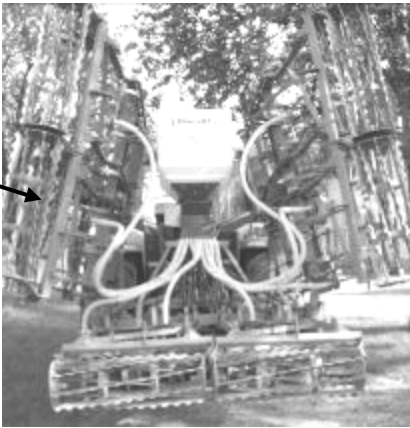

Please avoid fitting the hoses upwards or in sharp bends. Try to fit them gradient downwards.

Tipp: Use the foregoing hose as a support for the following.

6. When fitting the spreader plates start measuring from the center.

Tipp: Working width ÷ number of hoses = Right space between spreader plates!

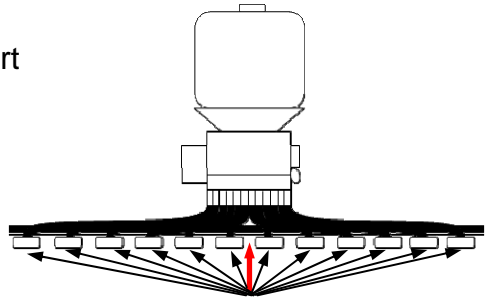

The position of the spreader plates can vary!  
They can be positioned vertical or horizontal.

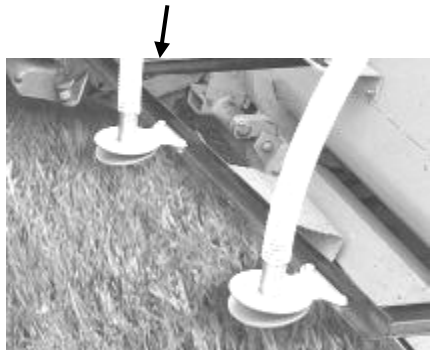

**The speed sensor** reacts to metal, therefore it is important to give pulses to the sensor. The pulses can be screws, which can be affixed on the inner wheel of the tractor or on a roller. The speed is named with mm/speed-pulse. The driven way between the pulses must be min. 1 mm to max. 500 mm.

Calculate the way as follows:

*For example:* You have a wheel with a diameter of 2m. The wheel amplitude ( $A_{\text{amplitude}} = D_{\text{diameter}} \times 3,14 \Rightarrow A=6,28$ ) is 6,28m = 6280mm. The maximum distance from pulse to pulse has to be under 500mm driven way. As a fact of this ( $6280/500=12,56$ ) you need **MINIMUM 13 signals**. Better to use about 20 signals. The signals can be fitted in any radius, but it is important that the speed-sensor is off between the signals.

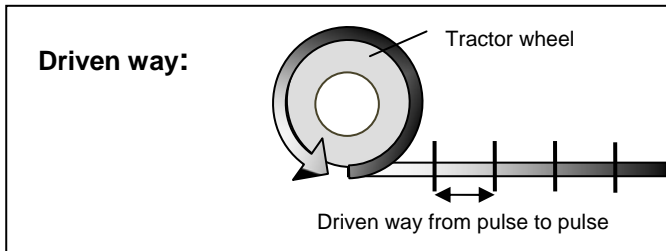

**Inspection of the pulses/signals:** When the signals are fitted, first it is important to check if the speed sensor counts the signals.

Attention! The sensor must count every signal (the light is on) (IMG. 1) and accordingly the sensor must be off between the signals (the light is off) (IMG 2).



IMG 1: The Light is on!



IMG 2: The Light is off!

**Problem handling:**

1. If there is no lightening, the problem can be, that there is too much space between the sensor and the signal (max. 8 mm).

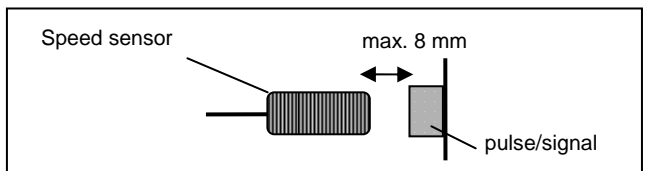

2. If the light is on, also between the signals, the problem is that the signals are too narrow to the next. So the signals must be fitted in an increased radius.

### Mounting-possibilities of speed sensor:



The **ON/OFF-sensor** stops the seed roll when it is in contact with the metal. The diameter of the sensor is 30 mm. The space between the metal and the sensor must be max. 8 mm.

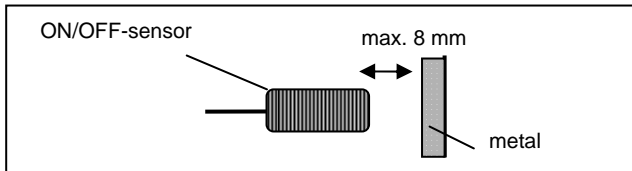

Attention! It is possible to change the polarity of the sensor.

Polarity-change as follows: The ON/OFF-sensor is one of three settings which can be changed. Changing the parameter is done by holding both SET button and RESET Button down for 2 seconds when the **kg/ha** value is displayed. Then press SET: The 1st parameter is displayed, press SET again to accept. Then the 2nd parameter is displayed, press also SET to accept. When the 3rd parameter (= parameter for changing polarity) is displayed, press UP or DOWN for changing this value ("0" or "1"). Press SET again and this value is accepted and saved.

### Mounting-possibilities of ON/OFF-sensor:



The speed sensor and the ON/OFF-sensor have the same function. They only differentiate in their diam (18mm and 30mm) and in their reacting difference (18mm-sensor: max. 4mm reacting difference; 30mm-sensor: max. 8mm reacting difference).

# Mounting possibilities of TP-Turbo-Jet Super:



## Mounting possibilities of TP-Turbo-Jet Super:

