

# ÖKO-TURBO Profi-Steuerung

Cable / Kabel 2x2,5mm<sup>2</sup>

Cable / Kabel 5x1,5mm<sup>2</sup>

Br .... Brown / Braun

Bl .... Blue / Blau

Bc .... Black / Schwarz

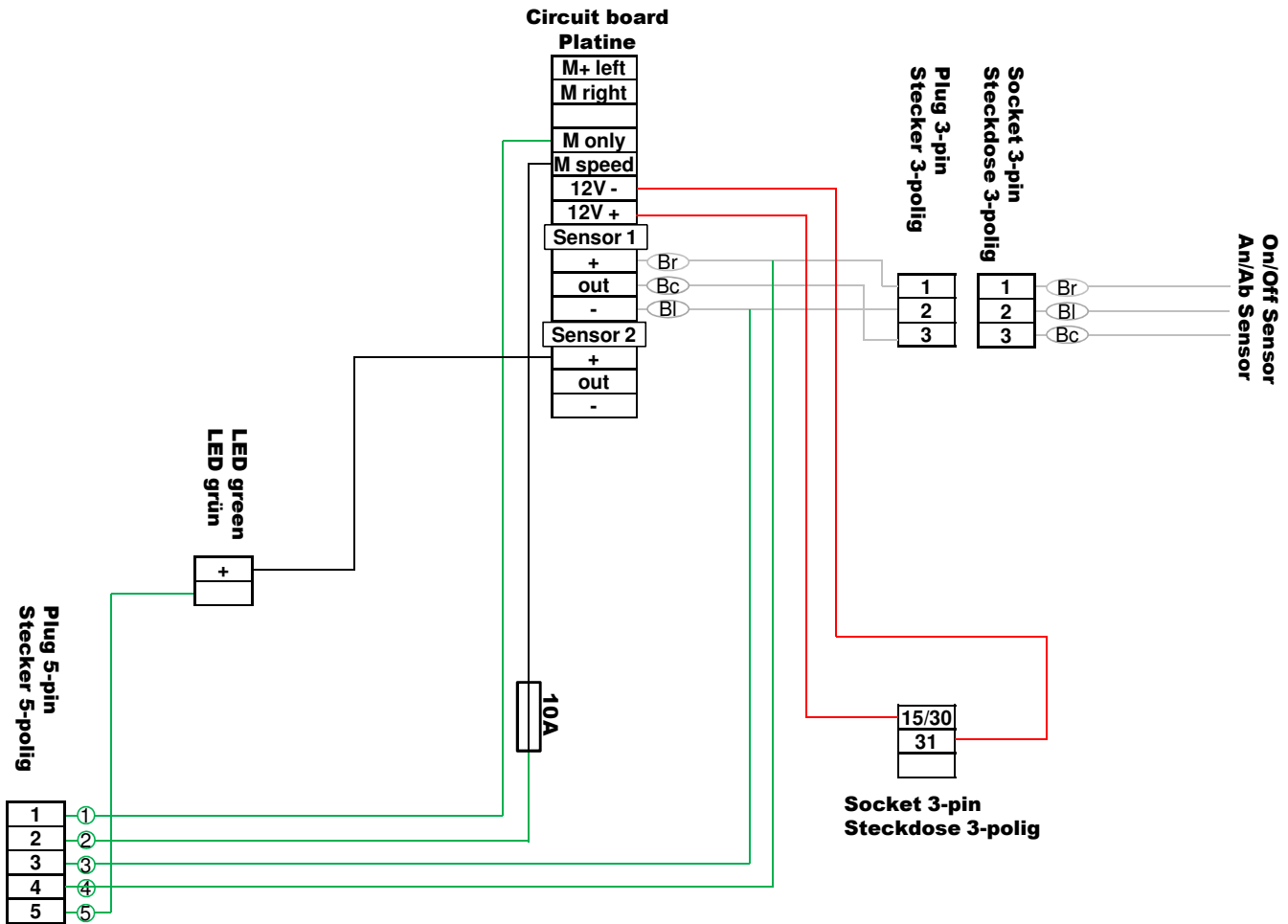

- |   |   |   |
|---|---|---|
| 1 | ① | Sensor signal (black cable) / Sensor signal (schwarzes Kabel)   |
| 2 | ② | + Seed roll motor (blue cable) and Sensor (brown cable) / + Säwellenmotor (blaues Kabel) und Sensor (braunes Kabel) |
| 3 | ③ | - Seed roll motor (black cable) / - Säwellenmotor (schwarzes Kabel)   |
| 4 | ④ |   |
| 5 | ⑤ | Sensor (blue cable) / - Sensor (blaues Kabel)   |

Socket 5-pin  
Steckdose 5-polig