

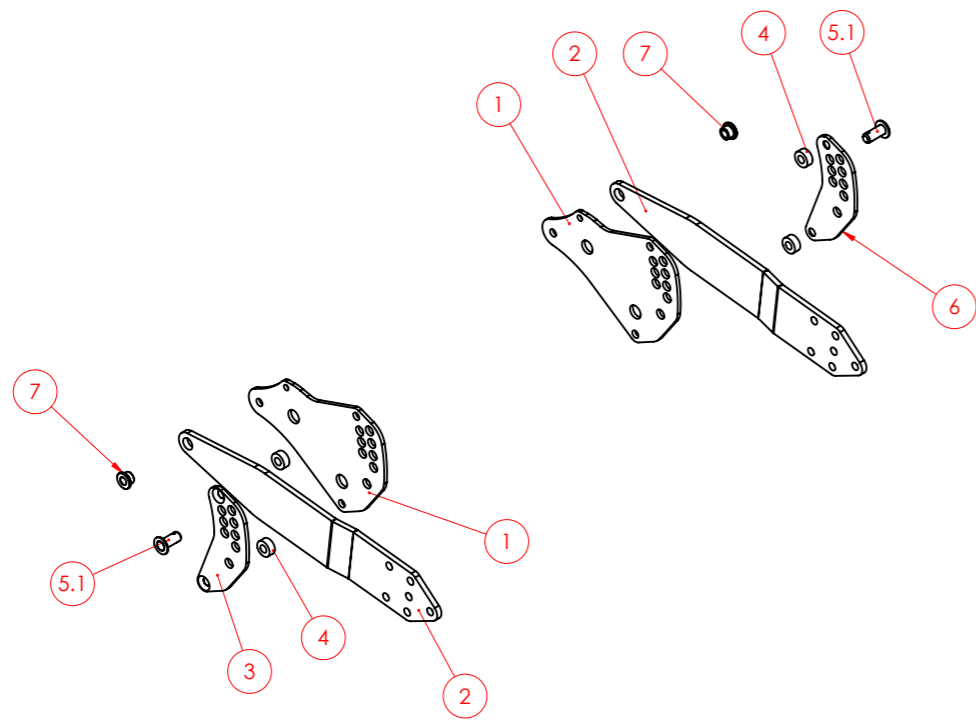

30	2	FF804304	RONDELLA	S355 60/10
29	2	FF804206	SPINA	ASS. SALD.
28	10	FF804205	BOCCOLA ALPEGO 16/35 - 18.5	TONDO S355 D.35 L.18.5
27	2	FF804123	SUPPORTO	S355 80/10
26	2	FF804122	RONDELLA 17-35-12	S355 120/10
25	2	FF804121	BIELLA COFANO	S355 100/10
24	4	FF804120	MANOVELLA	S355 100/10
23	6	FF804119	CERNIERA	S355 100/10
22	2	FF804118	COFANO INFERIORE	S355 40/10
21	2	FF804117	COFANO SUPERIORE	ASS. SALD.
20	2	FF804116	MARGHERITA	ASS. SALD.
19	1	FF804115	PERNO FILETTATO	ASS. SALD.
18	2	FF804114	RONDELLA	S355 60/10
17	1	FF804113	RIPUNTATORE	ASS. SALD.
16	2	FF804112	CONTENIMENTO RIDUTTORE	S355 40/10
15	2	FF804111	ROTORE FRESA	ASS. SALD.
14	2	FF804110		S355 40/10
13	2	FF804109		S355 40/10
12	2	FF804108	CONTENIMENTO	ASS. SALD.
11	2	FF804107	DISTANZIALE	S355 20/10
10	1	FF804106	BANDELLA DX	ASS. SALD.
9	1	FF804105	BANDELLA SX	ASS. SALD.
8	2	FF804104	COPRI RIDUTTORE	S355 40/10
7	4	FF804103	ATTACCO SOLLEVATORE	S355 100/10
6	1	FF804102	ATTACCO TERZO PUNTO	ASS. SALD.
5	1	FF804101	TELAIO FM 2018	ASS. SALD.
4	2	11000210	SUPPORTO AUTOALLINEANTE UCF 210	COMM.
3	1		SCATOLA FM	COMM.
2	1		ASSIEME ZAPPE	COMM.
1	8		BALESTRA COFANO D.6.4	COMM.
ITEM NO.	QTY.	PART NUMBER	DESCRIPTION	MATERIAL

	Note:						QUOTE SENZA INDICAZIONE DI TOLLERANZA ISO 2768-mK	
	Lavorazioni interne:	Laser 2D	Laser 3D	Laser Tubo	Stamp.	Pieg. Caland.		Saldatura
	Disegnatore:	Approvato		Materiale				ASSIEME
	Codice N°:	Foglio N°:	Data creazione:	Peso:	Tratt. termico:			
FF804100		04/07/2018	538.15 kg	Tratt. superficiale:				
Cliente:	Particolare:						FRESA 300	

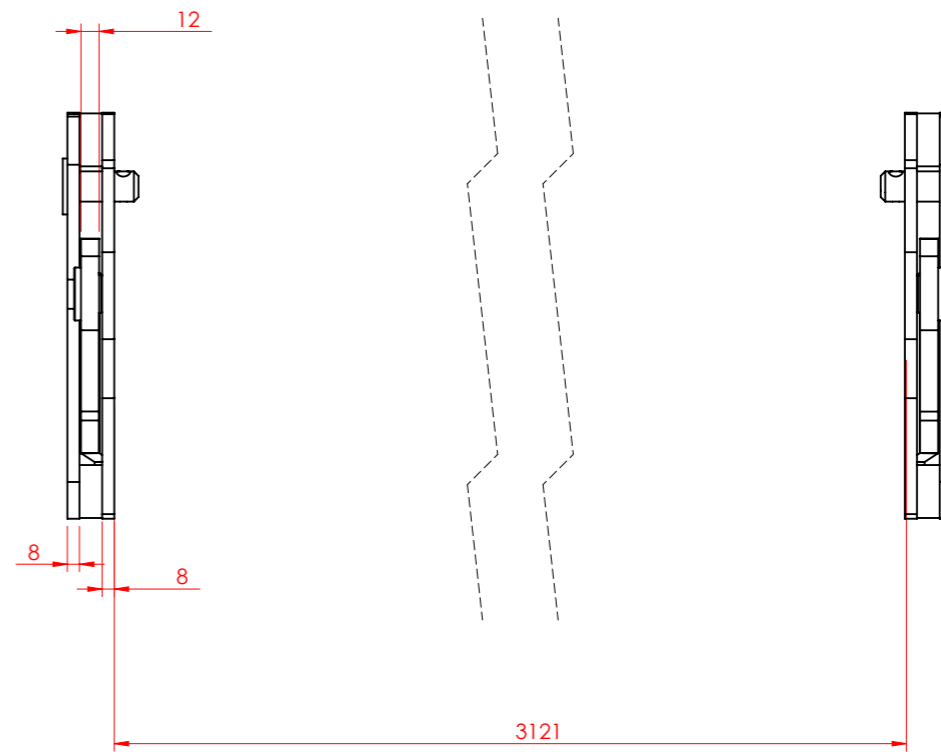
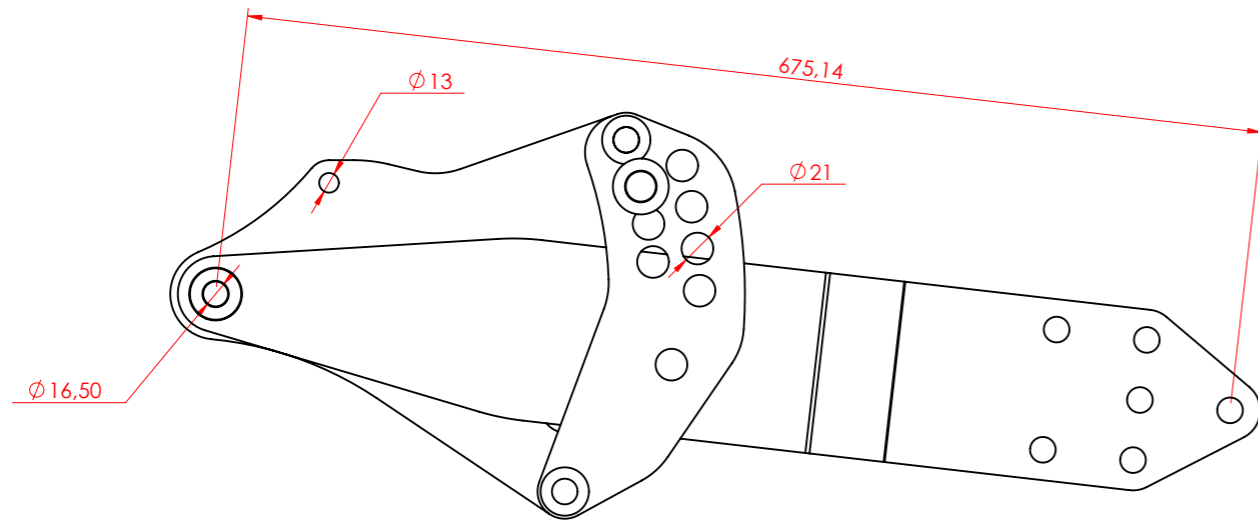

ITEM NO.	QTY.	PART NUMBER	DESCRIPTION	MATERIAL
1	2	FF804201		S355 80/10
2	2	FF804202		S355 120/10
3	1	FF804203		S355 80/10
4	4	P0702	RONDELLA 17-35-15	S355 150/10
5	2	FF804206	SPINA FERMARULLO	ASS. SALD.
5.1	1	FF804207	SPINA	TONDO TRAFILATO S355 D.20 L.50
5.2	1	13202001	RONDELLA ZINC. PIANA M20 UNI 6592	COMM.
6	1	FF804204		S355 80/10
7	2	FF804205	BOCCOLA ALPEGO 16/35 - 18.5	TONDO S355 D.35 L.18.5

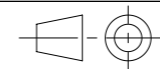
 CAVALLERETTI GROUP	Note:						QUOTE SENZA INDICAZIONE DI TOLLERANZA ISO 2768-mK	
	Lavorazioni interne:	Laser 2D	Laser 3D	Laser Tubo	Stamp.	Piega Coland.		Saldatura
Codice N°: FF804200	Foglio N°:	Disegnatore:		Approvato	Materiale ASSIEME			
Data creazione: 04/07/2018		Peso: 23.78 kg		Tratt. termico:				
		Scala:		Tratt. superficiale:				
Cliente:		Particolare:						SUPPORTO RULLO

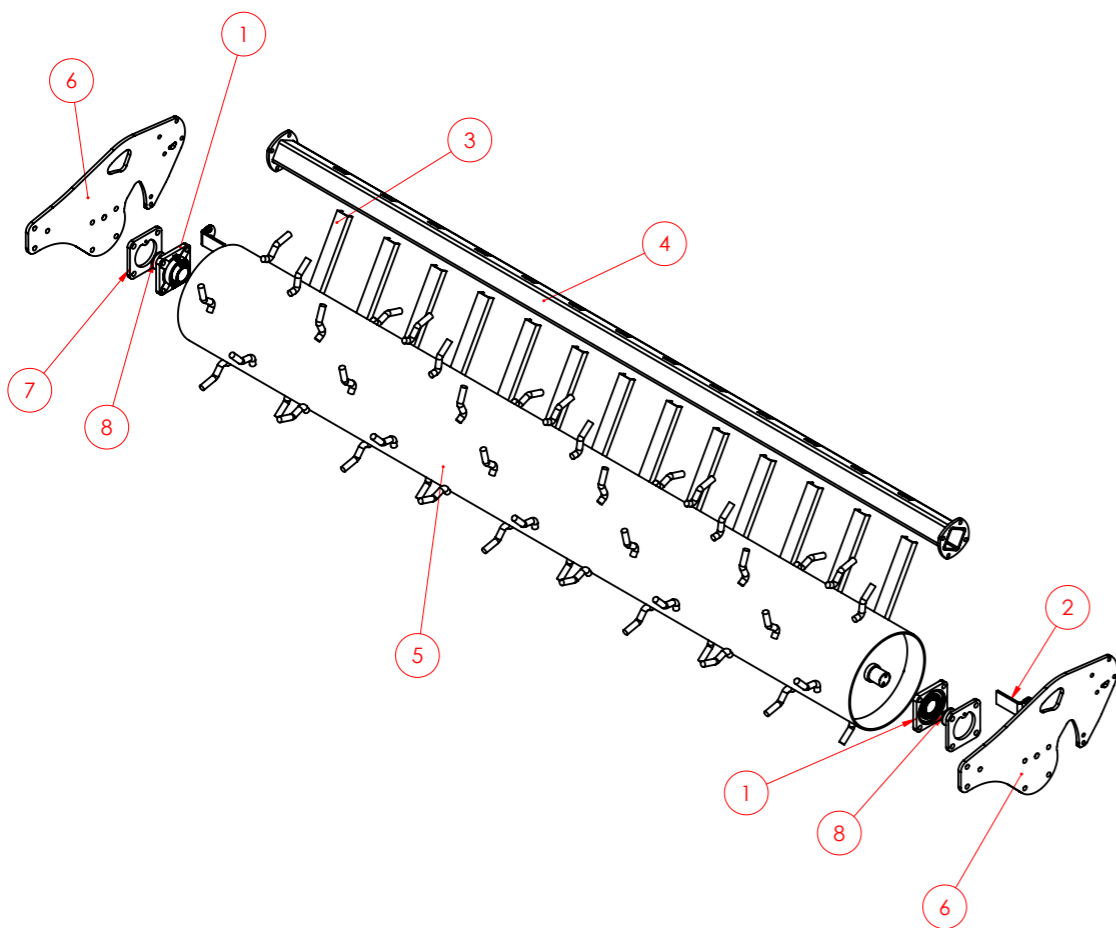
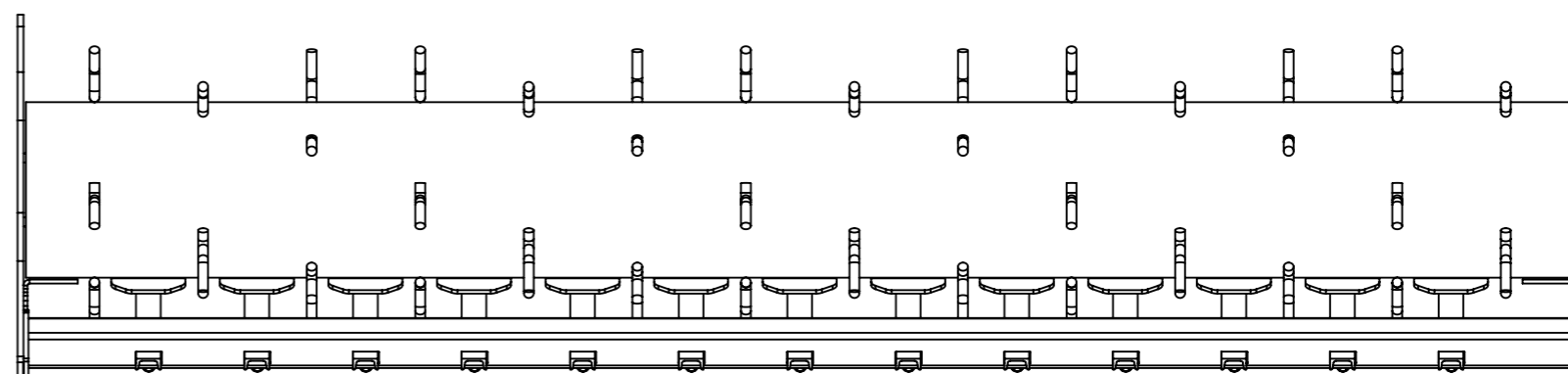
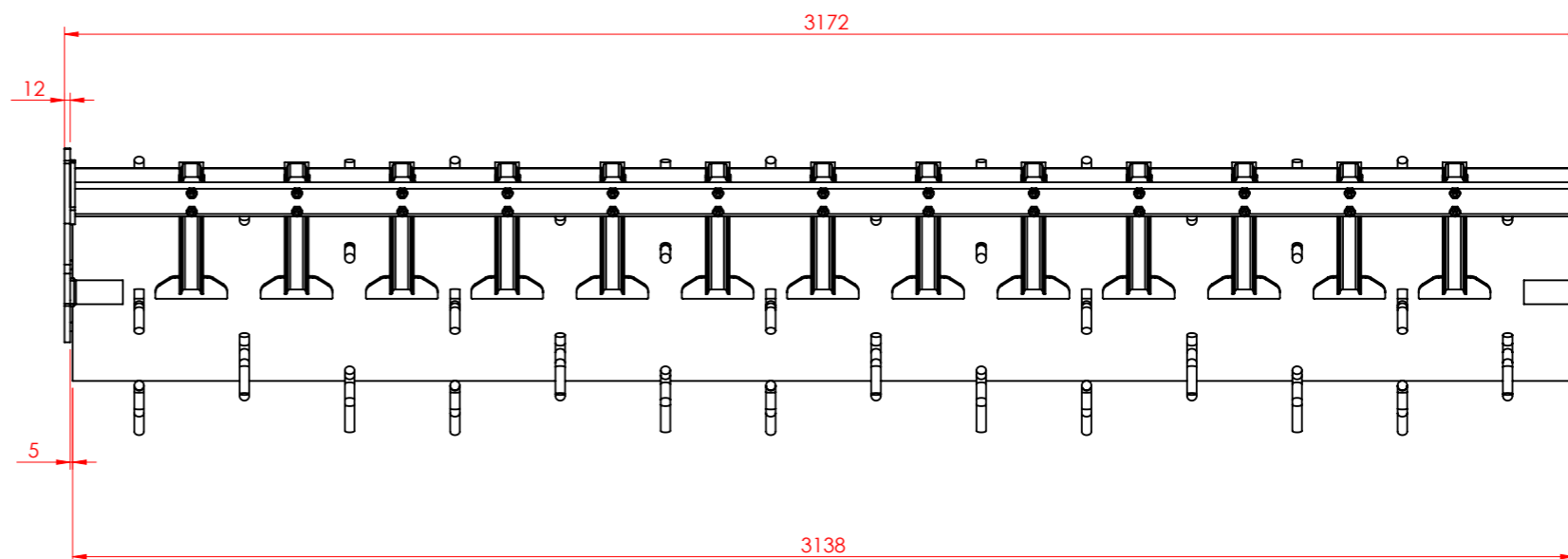
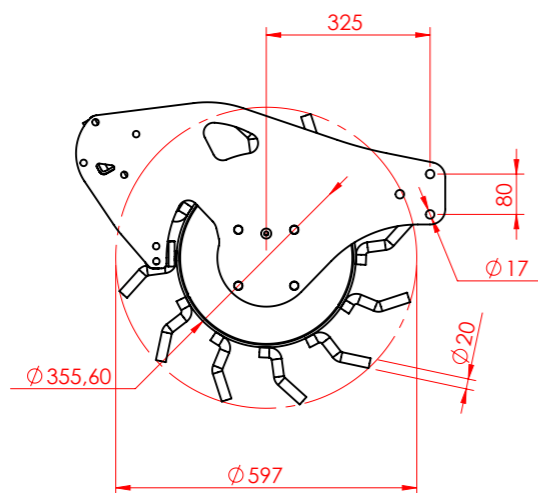

ITEM NO.	QTY.	PART NUMBER	DESCRIPTION	MATERIAL
8	2	FF804304	RONDELLA	S355 60/10
7	2	FF804303	DISTANZIALE	S355 120/10
6	2	FF804302	BANDELLA	S355 120/10
5	1	FF804301	RULLO D.355/600 L.3138	ASS. SALD.
4	1	30330705	TUBO QUADRO RULLO	ASS. SALD.
3	13	30300707	RASCHIATORE RULLO SPUNTONI 2013	ASS. SALD.
2	2	30200708	RASCHIATORE ESTERNO	S355 80/10
1	2	11000210	SUPPORTO AUTOALLINEANTE UCF 210	COMM.



**CAVALLERETTI
GROUP**

Note:

Lavorazioni interne:	Laser 2D	Laser 3D	Laser Tubo	Stamp.	Piega Caland.	Saldatura
----------------------	----------	----------	------------	--------	---------------	-----------

Disegnatore: Approvato

Materiale: **ASSIEME**

Data creazione: **04/07/2018**

Peso: **272.83 kg**

Tratt. termico:

Tratt. superficiale:

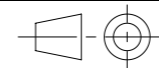
Scala: 

Particolare: **RULLO SPUNTONI D.355**

QUOTE SENZA
INDICAZIONE DI
TOLLERANZA
ISO 2768-mK

Codice N°: **FF804300** Foglio N°:

Cliente: